

A

B

C

D

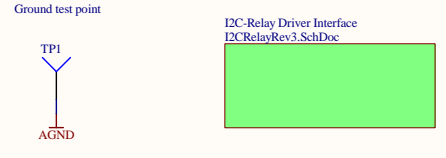
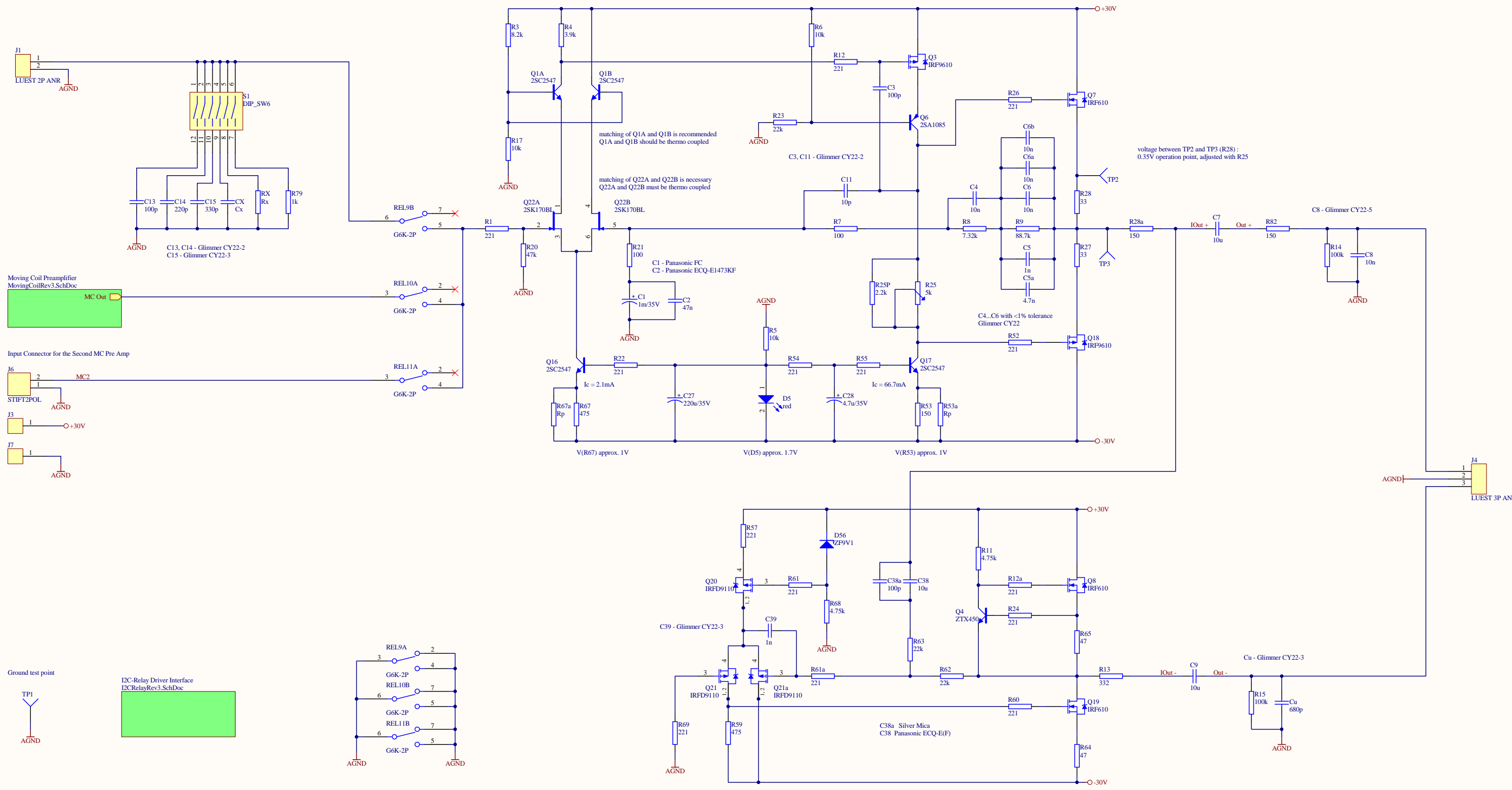

different types of possible 10u output coupling caps
C7d, C9d Silver Mica

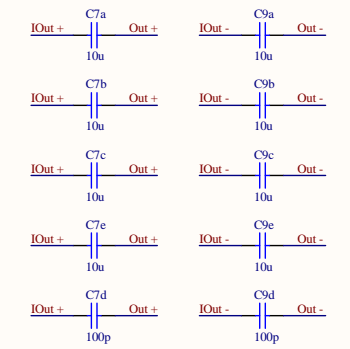

Rev. 3
 BC550C changed to ZTX450 and 2SC2547
 BC560C changed to ZTX550 and 2SA1085
 R53a & R67a included to trim the current sources Q16 and Q17
 C7, C9 - Mundorf Supreme Caps
 C38 - Panasonic ECQ-E1106KF
 include REL9 - REL11 include
 Replacement of LM317/337 with a Voltage Regulator Module

Title			
VV5 Preamp - XOno Moving Magnet Phono Preamp			
Size	Number	Revision	3
A2	RSTA0026.3		
Date:	27.02.2012	Sheet of	
File:	C:\User\...MovingMagnetRev3.SchDoc	Drawn By:	Ralph Stens